

SU-EM-G1 Series

Emergency driver for Supply Line hook-up

DESCRIPTION

- AC solution EM for most 9~350W LED luminaire.
- It must connect 0/1-10V dimming wires if power of luminaire > power of emergency.

FEATURES

- UL listed for field or factory installation,CEC title 20 compliant
- Compliance with American NFPA 101 life Safety Code
- Constant output power
- 2 -in- 1 LED test switch and indicator light included
- Manual testing via remote control (optional)
- Monthly/annual self-testing
- With multi-protection function:
 - Battery overcharge protection
 - Battery over-discharge protection
 - Output overload protection
 - Short-circuit protection
 - Open load protection
- 5 years limited warranty



ELECTRICAL SPECIFICATIONS

- Input voltage: 100-347VAC,50/60Hz
- Input current: 0.15A max
- Input power: 12W Max
- Power factor: 0.6 @100VAC, 0.5@347VAC
- Input of LED load: AC 6A Max
- Battery: Lithium
- Recharge duration: < 24Hrs
- Emergency duration: 90mins
- Ambient temp: 0-50°C(32°F-122°F)



Self Test

MODEL SELECTION TABLE

Models	Emergency wattage	Battery capacity	Compatible led fixture
SU-EM-25WA-G1	25W	14.4V/4400mAh	25-200W LED lamp with 0-10V dimming or 10-24W LED lamp without 0-10V dimming
SU-EM-40WA-G1	40W	14.4V/6600mAh	40-350W LED lamp with 0-10V dimming or 10-39W LED lamp without 0-10V dimming

NORMAL MODE

Fixtures will operate normally when power is available. When an outage occurs, the fixture will switch to emergency mode, delivering power to the fixture for up to 90 minutes.

EMERGENCY MODE

1. The emergency battery backup enters the emergency mode immediately after the mains power failure.
2. Stop the emergency and return to the charging state after the mains power call.

SELF-DIAGNOSTIC

MONTHLY SELF-TEST

It will automatically perform a monthly self-test every 30 days with a duration of 30S to check whether the emergency function is normal, and automatically restore to normal charging after 30S discharged.

ANNUAL SELF-TEST

An annual self-test will be done every year (12 months) with a duration of 90mins to check whether the capacity of the battery pack is normal, and automatically restore to normal charging after fully discharged. (the condition of annual test is that the battery pack is fully charged).

If the annual inspection is interrupted, it will be retested after recovery and when the test conditions are met. (Possibility of interruption: such as sudden power failure, sudden manual test).

TEST BUTTON & LED INDICATOR

Operations	Test button operations	Remote control operations	Indicator status	Working status
Normal mode	Long press the test button	Press button A	OFF	Emergency mode
	/	Press button B	OFF	Monthly testing
	/	Press button C	OFF	Annual testing
	/	/	ON	Battery is charging or fully charged
	Press the test button 5 times within 5S	Press button D 10S	Flashing 3 times	Bluetooth reset
Emergency mode	Press the test button 5S	/	OFF	Turn off the battery pack
Malfunction mode	/	/	Flashing	1.The battery pack is disconnected or it is broken. 2.The load is disconnected. 3.Short circuit or open circuit. 4.The wires are not connected properly.

*Note:After power on the Bluetooth EM, LED red indicator light breathing when unprovisioned, red indicator light keeps on means the EM device has been connected by another user and weren't correctly disconnected, please use the remote control to reset it or press the test button 5 times within 5S to reset the EM.

ACCESSORIES



15pcs wire nuts



1pc test plate

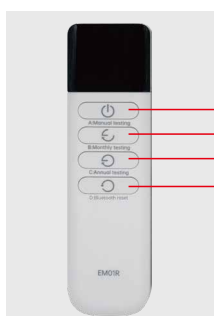

1pc remote control
*Optional

- A: Manual testing
- B: Monthly testing
- C: Annual testing
- D: Bluetooth reset

SU-EM-G1 Series

Emergency driver for Supply Line hook-up

DIMENSION

Model	L	W	H
SU-EM-25WA-G1	12.24 " (311mm)	2.59 " (66mm)	1.53 " (39mm)
SU-EM-40WA-G1	12.24 " (311mm)	2.59 " (66mm)	1.53 " (39mm)

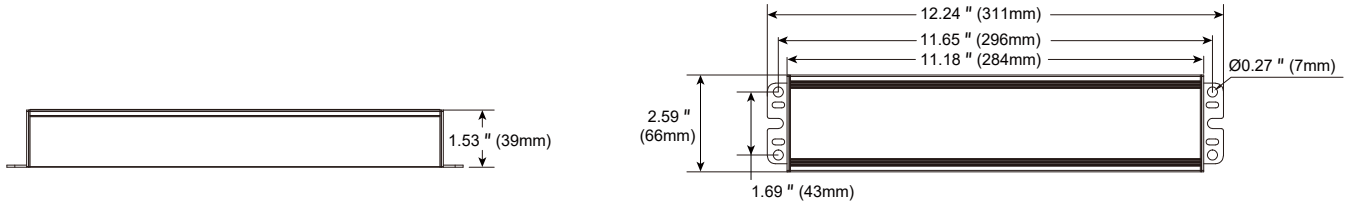

WIRING DIAGRAM

A: With dimmer, when power of luminaire \geq power of emergency, the wiring diagram as below:

* The output dimming wires of Emergency Driver must be connected with the input dimming wires of the LED Driver.

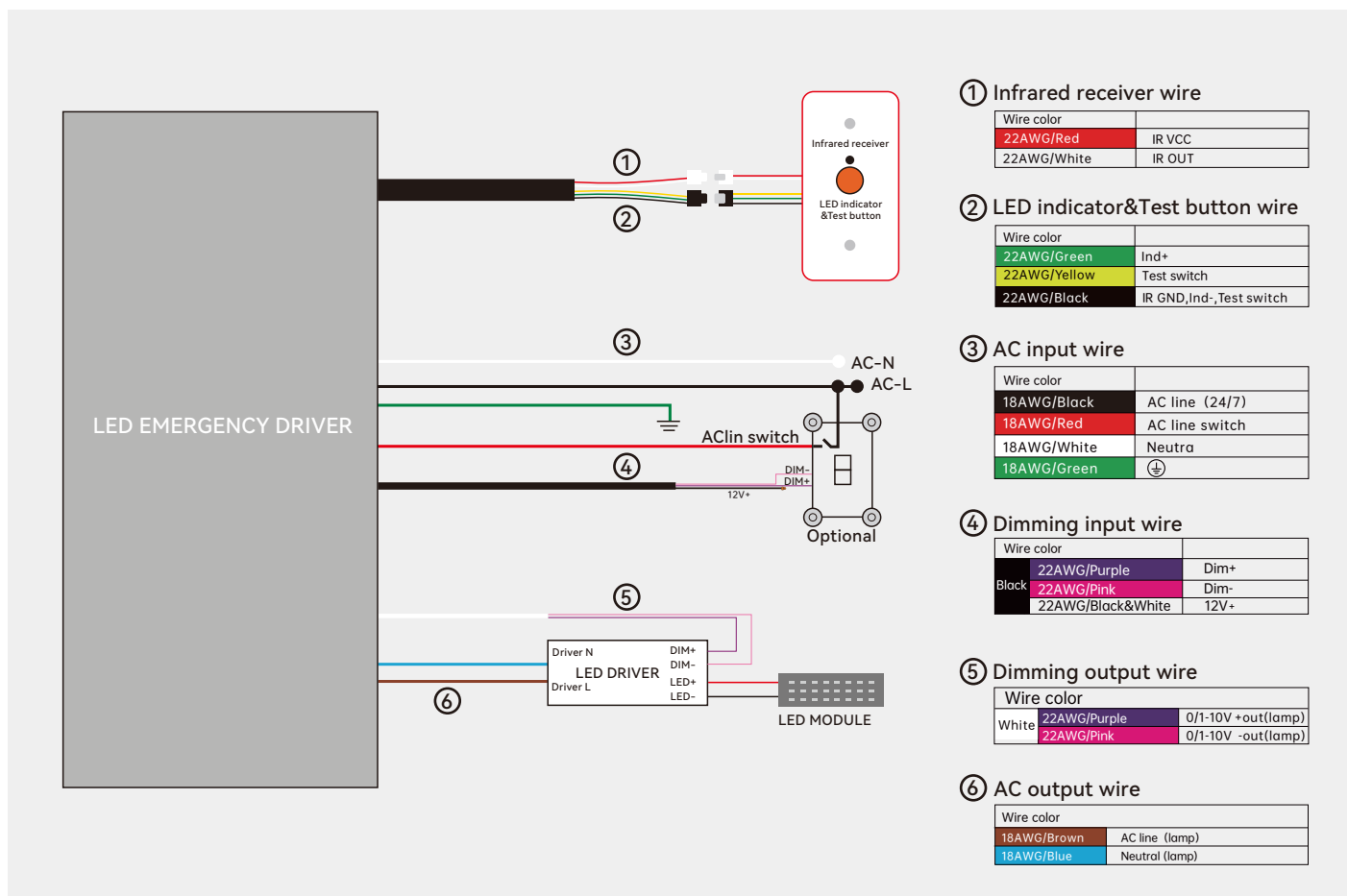

⚠ Warning: Sensor and dimmer cannot be used at the same time!

SU-EM-G1 Series

Emergency driver for Supply Line hook-up

B: With sensor, when power of luminaire \geq power of emergency, the wiring diagram as below:

* The output dimming wires of Emergency Driver must be connected with the input dimming wires of the LED Driver.

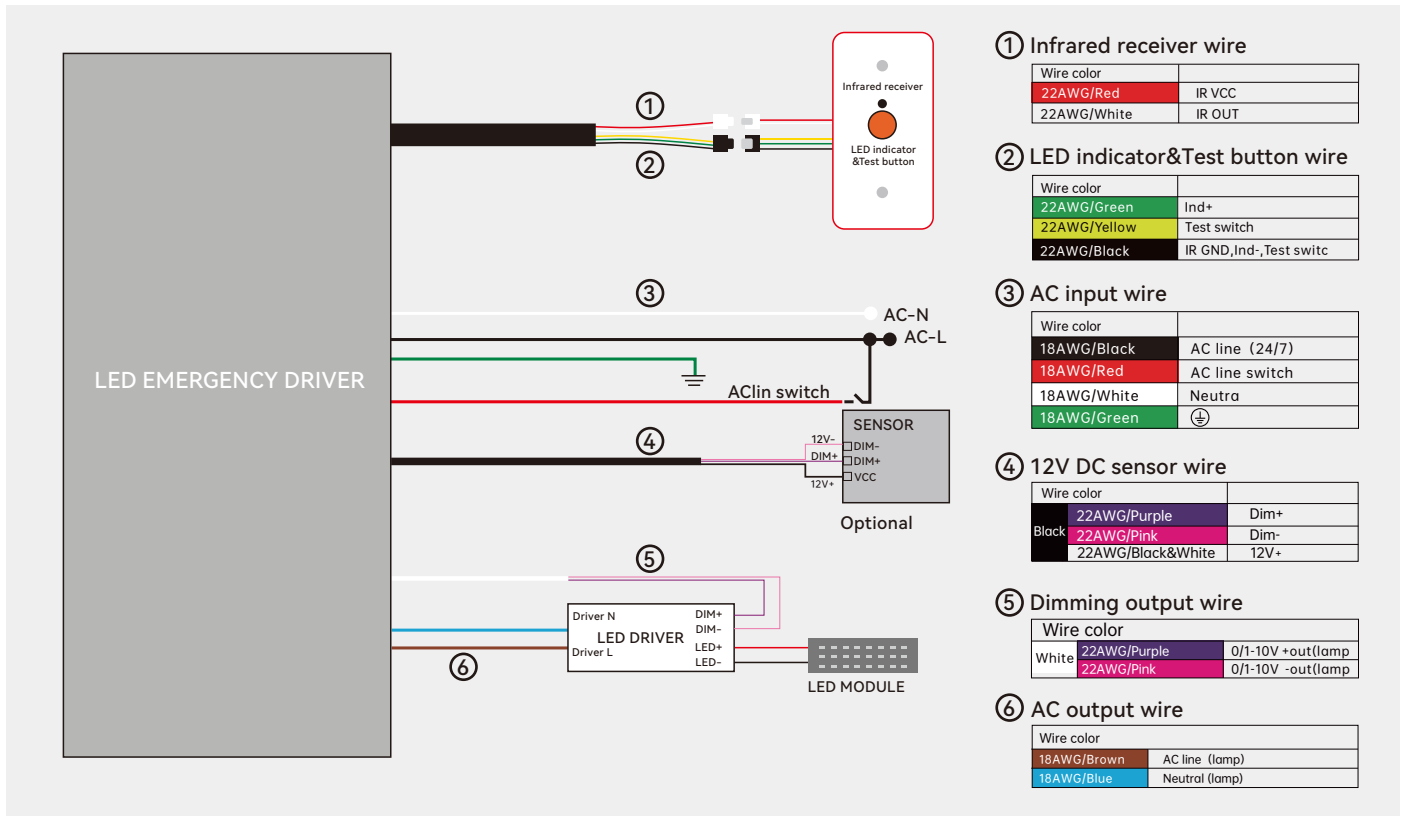

⚠ Warning: Sensor and dimmer cannot be used at the same time!

C: With dimmer, when power of luminaire $<$ power of emergency, the wiring diagram as below:

* The output dimming wires of Emergency Driver must not be connected with the input dimming wires of the LED Driver.

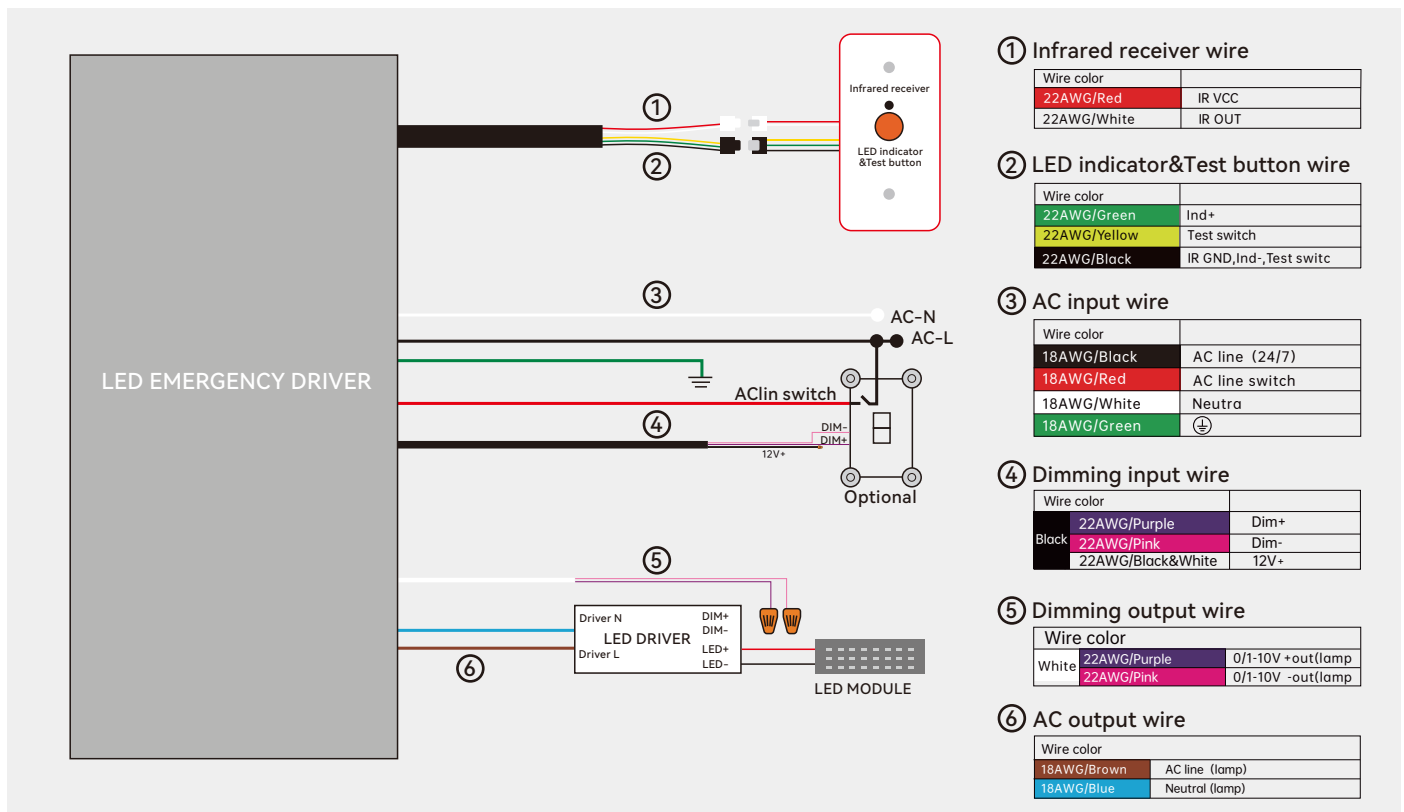

⚠ Warning: Sensor and dimmer cannot be used at the same time!

D: With sensor, when power of luminaire < power of emergency, the wiring diagram as below:

* The output dimming wires of Emergency Driver must not be connected with the input dimming wires of the LED Driver.

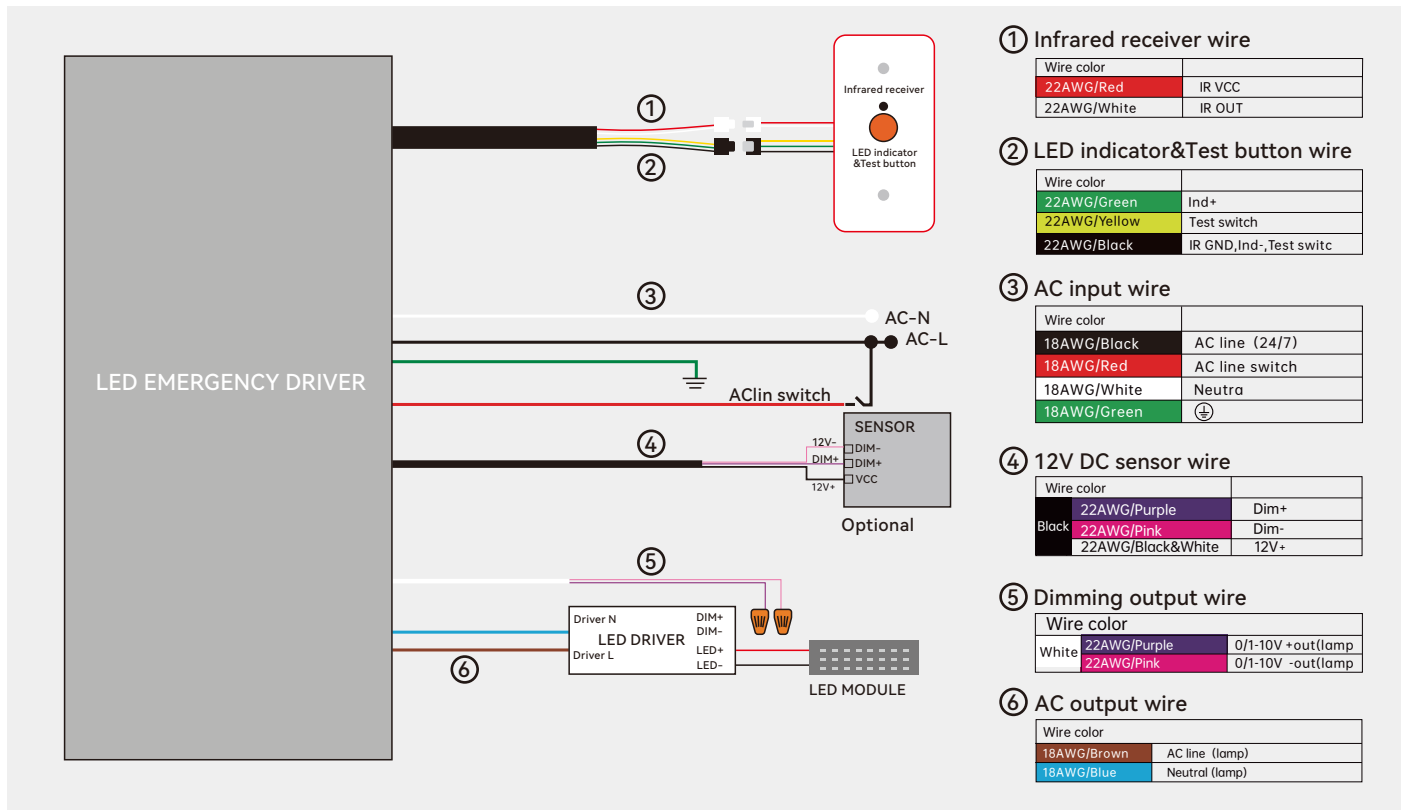

⚠ Warning: Sensor and dimmer cannot be used at the same time!

IMPORTANT SAFEGUARDS

When using electrical equipment, basic safety precautions should always be followed, including the following:



CAUTION

READ AND FOLLOW ALL SAFETY INSTRUCTIONS



1. CAUTION – To prevent electrical shock, do not mate unit connector until installation is complete and AC power is supplied to the unit.
2. CAUTION – This fixture provides more than one power supply output source. To reduce the risk of electrical shock, disconnect both normal and emergency sources by turning off the AC branch circuit and by disconnecting the unit connector.
3. CAUTION – This is a sealed unit. Components are not replaceable. Replace the entire unit when necessary.
4. CAUTION – Installation and servicing should be performed by qualified personnel only. De-energize before opening.
5. The series is for use with grounded LED luminaires listed to UL standards. Not for use in heated air outlets or hazardous locations.
6. The series requires an unswitched AC power source of 100 to 347 volts, 50/60 Hz.
7. The series and AC driver must be on the same branch circuit.
8. Do not mount near gas or electric heaters.
9. The series should be mounted in locations and at heights where it will not readily be subjected to tampering by unauthorized personnel.
10. The series will supply 145 VDC output at the individual rated specification for 90 minutes.
11. Suitable for use in damp locations and plenum spaces.
12. Flexible metal conduit is optional, depends on installation environment.
13. For use in 0° C minimum, 50° C maximum ambient temperatures.
14. Do not use this equipment for other than intended use.
15. Install in accordance with the National Electrical Code and local regulations.
16. Lighting fixture manufacturers, electricians, and end-users need to ensure product system compatibility before final installation.