



## FEATURES & SPECIFICATIONS



### ALL IN ONE

5 Powers Adjustable & 3 CCT Option

### IP Rating

LED light engine rated IP66. Driver compartment rated to IP65.

### Optical System

Typell(standard), Types IV and Distributions Available.

### LEDS

RA>80, R9>0, Long-life, high-efficacy, SMD 3030 EMC

### Mounting

Slip Fitter Mount (standard), Square & Round Pole Mount, Trunnion Mount

### Operating temperature

-4°F~104°F

### Warranty

Five years Warranty

### Construction

Die-cast aluminum housing & Driver housing

### Finish

powder coated, post-painted black or white

### Driver

SOSEN 120-277V, 10KV Surge Protection, 0-10V Dimming

### Control

Photocell Sensor Base, NLC Occupancy Plug & Play Sensor Base

### Lifespan

L70>50,000 hours.

### Certifications

ETL Listed, FCC, DLC 5.1 Premium.







## Order Information

Dimension	Part No.	Power	@Max Power 5000K		Input Voltage	CCT
			Efficacy	Flux		
17.4 x11.1 x2.4 inch	SU-AL-240W-XXK G8	100W-170W-200W-220W-240W	140 lm/W	42000 lm	120-277V	2CCT

"Note: 2CCT=50K-57K"

## Accessories

NLC Motion&Daylight Sensor	Photocell Sensor	Shorting Cap	10KV Surge Protection Device
			

## PRODUCT DIMENSIONS

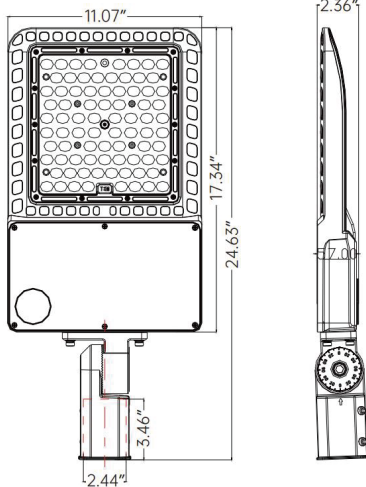
<p>17.34 x 11.07 x 2.36 Inch</p>	
----------------------------------	--

## Packing / weight

Model	Outer Box (L x W x H)	Qty/Ctn (pcs)	G. W/Ctn (lbs)	Container 40HQ
EDI-AL-240W G8	675 x 330 x 125 mm 26.6 x 13.0 x 4.9 inch	1	5.5 KG 12 LBS	2300 pcs

## Warranty

This product has a warranty of period of 5 years from the date of purchase. The warranty is invalid in the case of improper use, installation, tampering or removal of the Q.C. and/or date label, usage in improper working environment or installation not according to the current edition of the National Electric Code. Should this product fail during the warranty period it will be replaced free of charge, subject to correct installation and return of the faulty unit. Manufacturer does not accept responsibility for any installation costs associated with the replacement of this product. This warranty is in addition to the statutory rights in your country of purchase. Manufacturer reserves the right to alter specifications without prior notice.

## Note

- 1.The installation and maintenance must be completed by electricians or professionals.
- 2.Please cut off the power before installation and maintenance.
3. The thermally insulating material is not allowed to cover the fixture.
4. Please keep away from the corrosive substance, and keep the fixture dry and clean.
- 5.Working temperature: -4°F~104°F, storage temperature: -22°F~140°F.